

Express

COLONIAL SERIES CABINET SPECIFICATIONS

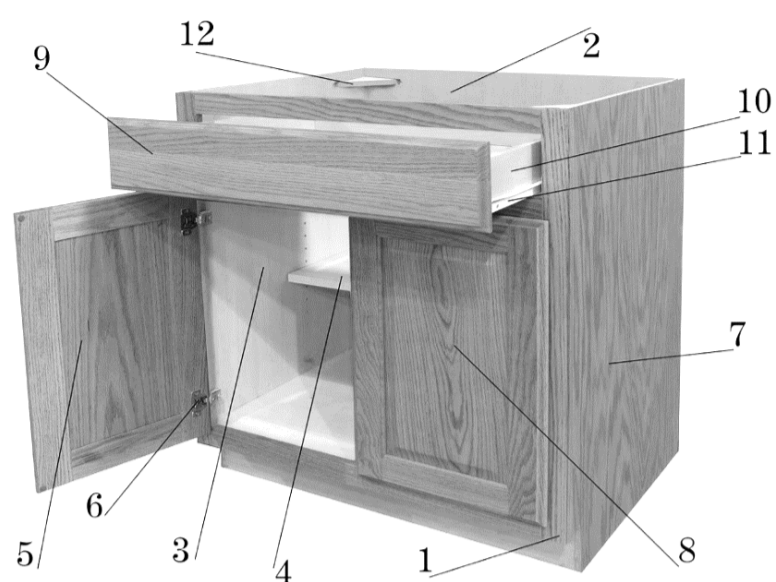

BASE CABINET

WALL CABINET

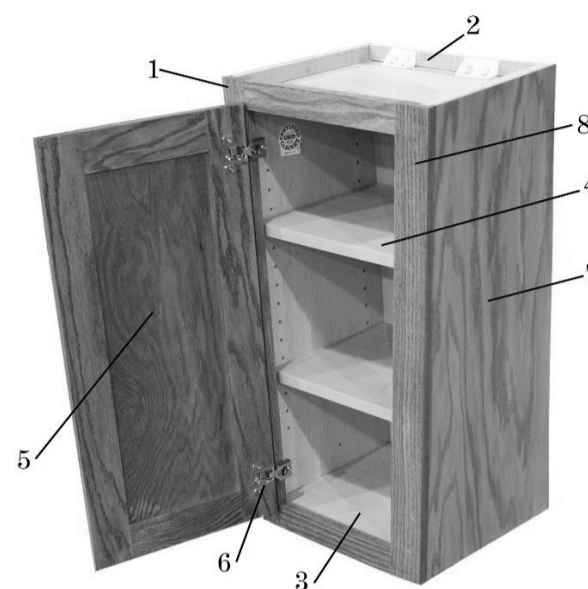

***Colonial series is not available with printed ends.
Skins must be used for exposed cabinet sides**

1. 3/4" HARDWOOD FACE FRAMES WITH GLUED AND POCKET SCREWED JOINTS.
2. 1/2" PLYWOOD BACK WITH MAPLE PRINT INTERIOR, ELIMINATING THE NEED FOR HANG RAILS. WALL CABINETS OVER 36" WIDE WILL HAVE SHELF HOLES IN THE BACK.
3. 1/2" PLYWOOD SIDES, TOPS AND BOTTOMS, WITH MAPLE PRINT INTERIOR AND EXTERIOR.
4. 3/4" PLYWOOD SHELVING WITH MAPLE PRINT ON BOTH SIDES AND ONE EDGE. ALL SHELVES ARE ADJUSTABLE WITH BASE CABINETS HAVING 1/2 DEPTH SHELVES, SUPPORTED BY SHELF CLIPS.
5. DOORS WILL BE 1/4" VENEERED FLAT PANEL OR 9/16" VENEERED RAISED PANEL WITH HARDWOOD STILES AND RAILS.
6. BLUM ONE PIECE ADJUSTABLE CONCEALED HINGES WITH LIFETIME WARRANTY.
DOOR UPGRADE OPTIONS:
 1. BLUMOTION SOFT CLOSE HINGE
7. ENDS WILL BE MAPLE PRINT
8. STANDARD FINISH CONSISTS OF HAND WIPED STAIN, A COAT OF SELF SEALING CONVERSION VARNISH & A TOP COAT OF CONVERSION VARNISH. FINISH THICKNESS APPROXIMATELY 7 MIL, WET.
9. 3/4" HARDWOOD DRAWER FRONTS. BIRCH WITH PAINT WILL BE HIGH DENSITY FURNITURE BOARD
10. 1/2" RABBETED PLYWOOD DRAWER WITH 1/4" FLOOR, FACED WITH MAPLE PRINT.
DRAWER UPGRADE OPTIONS:
 1. 5/8" SOLID HARDWOOD DOVETAIL DRAWER WITH SOFT CLOSE 7/8 EXTENSION UNDERMOUNT GUIDE.
 2. 5/8" SOLID HARDWOOD DOVETAIL DRAWER WITH 3/4 EXTENSION SIDEMOUNT GUIDE.
11. SELF ADJUSTING EPOXY COATED SIDE MOUNT DRAWER GUIDES. TRACK WEIGHT RATING OF 75 POUNDS.
12. COUNTERTOP CORNER STRETCHERS ARE MADE OF ENGINEERED WOOD.

DURING INSTALLATION IF SILICONE IS GOING TO BE USED WE RECOMMEND IT BE A "NEUTRAL CURE" SILICONE. SILICONE PRODUCTS THAT CONTAIN ACETIC ACID SHOULD NOT BE USED AS IT CAN HAVE A DISCOLORING EFFECT ON THE FINISH.

**KCMA CERTIFIED
MEETS KCMA ESP STANDARDS
C.A.R.B. PHASE II COMPLIANT**